

Solar inverters

ABB string inverters PVI-3.0/3.6/3.8/4.2-TL-OUTD 3.0kW to 4.2kW



This family of single-phase string inverters complements the typical number of rooftop solar panels enabling home-owners to get the most efficient energy harvesting for the size of the property.

This inverter offers a dual input section that processes two strings with independent Multiple Power Point Tracking (MPPT).

This is especially useful for rooftop installations with two different orientations from two sub-arrays oriented in different directions. (For example: East and West)
The dual input sections with independent MPPT enable a more optimal energy harvesting condition.

The high-speed MPPT offers real-time power tracking and improved energy harvesting.

The flat efficiency curve ensures high efficiency at all output levels allowing a consistent and stable performance across the entire input voltage and output power range.

The transformerless operation gives the highest efficiency of up to 97.0%. The wide input voltage range makes the inverter suitable to low power installations with reduced string size. This rugged outdoor inverter has been designed to be a completely sealed unit able to withstand the harshest environmental conditions.

Highlights:

- Single phase and split phase output grid connection.
- Wide input range for increased stringing flexibility.
- The high speed and precise MPPT algorithm offers real time power tracking and improved energy harvesting.
- Outdoor NEMA 4X rated enclosure for unrestricted use under any environmental conditions.
- Integrated DC disconnect switch in compliance with international Standards (-S Version).

Power and productivity
for a better world™



Additional highlights:

- RS-485 communication interface (for connection to laptop or data logger).
- Integrated Arc Fault Detection and Interruption (-A Version).



Technical data and types

Type code	PVI-3.0-OUTD-US			PVI-3.6-OUTD-US			PVI-3.8-OUTD-US			PVI-4.2-OUTD-US		
Mechanical specifications												
Nominal output power	3000W			3600W			3300 W			3800W		
Maximum output power wattage	3000 W	3300 ¹ W	3300 ¹ W	3600 W	4000 ¹ W	4000 ¹ W	3300 W	4200 ¹ W	4200 ¹ W	4200 W	4600 ¹ W	4600 ¹ W
Rated grid AC voltage	208V	240V	277V	208V	240V	277V	208V	240V	277V	208V	240V	277V
Input side (DC)												
Number of independent MPPT channels	2			2			2			2		
Maximum usable power for each channel	2000W			3000W			3000W			3000W		
Absolute maximum voltage (Vmax)	600V											
Start-up voltage (Vstart)	200V (adj. 120-350V)											
Full power MPPT voltage range	160-530V			120-530V			140-530V			140-530V		
Operating MPPT voltage range	0.7 x Vstart - 580V (>=90V)											
Maximum current (Idcmax) for both MPPT in parallel	20A			32A			32A			32A		
Maximum usable current per channel	10A			16A			16A			16A		
Maximum short circuit current limit per channel	12.5A			20.0A			20.0A			20.0A		
Number of wire landing terminals per channel	2 pairs											
Array wiring termination	Terminal block, pressure clamp, AWG10-AWG4											
Output side (AC)												
Grid connection type	1Ø/ 2W	Split- Ø/3W	1Ø/ 2W	1Ø/ 2W	Split- Ø/3W	1Ø/ 2W	1Ø/ 2W	Split- Ø/3W	1Ø/ 2W	1Ø/ 2W	Split- Ø/3W	1Ø/ 2W
Adjustable voltage range (Vmin-Vmax) (V)	183 - 228V	211 - 264V	244 - 304V	183 - 228V	211 - 264V	244 - 304V	183 - 228V	211 - 264V	244 - 304V	183 - 228V	211 - 264V	244 - 304V
Grid frequency	60Hz											
Adjustable grid frequency range	57-60.5Hz											
Maximum current (Iac,max)	14.5 A _{RMS}	14.5 A _{RMS}	12.0 A _{RMS}	17.2 A _{RMS}	16.0 A _{RMS}	16.0 A _{RMS}	16.0 A _{RMS}	16.0 A _{RMS}	16.0 A _{RMS}	20.0 A _{RMS}	20.0 A _{RMS}	20.0 A _{RMS}
Power factor	> 0.995											
Total harmonic distortion at rated power	< 2%											
Grid wiring termination type	Terminal block, Pressure clamp, AWG10-AWG4											
Input protection devices												
Reverse polarity protection	Yes											
Over-voltage protection type	Varistor, 2 for each channel											
PV array ground fault detection	Pre start-up Riso and Dynamic GFDI (requires floating arrays)											
Output protection devices												
Anti-islanding protection	Meets UL 1741/IEEE1547 requirements											
Over-voltage protection type	Varistor, 2 (L ₁ - L ₂ / L ₁ - G)											
Maximum AC OCPD Rating	20A _{RMS}	20A _{RMS}	15A _{RMS}	25A _{RMS}	20A _{RMS}	20A _{RMS}	20A _{RMS}	20A _{RMS}	20A _{RMS}	20A _{RMS}	25A _{RMS}	25A _{RMS}
Efficiency												
Maximum efficiency	96.9%			97%			97%			97%		
CEC efficiency	96%											
Operating performance												
Night time consumption	< 0.6W _{RMS}											
Stand-by consumption	< 8W _{RMS}											
Communication												
User-interface	16 characters x 2 lines LCD display											
Remote monitoring (1xRS485 incl.)	VSN700 Data Logger (opt.)											
Environmental												
Ambient air operating temperature range	-13°F to +140°F with derating above 122°F (50°C)											
Ambient air storage temperature range	-40°F to +176°F (-40°C to +80°C)											
Relative humidity	0-100% RH condensing											
Acoustic noise emission level	< 50 db (A) @1m											
Maximum operating altitude without derating	6560 ft (2000 m)											

1. Capability enabled at nominal AC voltage and with sufficient DC power available.

Block diagram of PVI-3.0, 3.6, 3.8, 4.2 -TL-OUTD

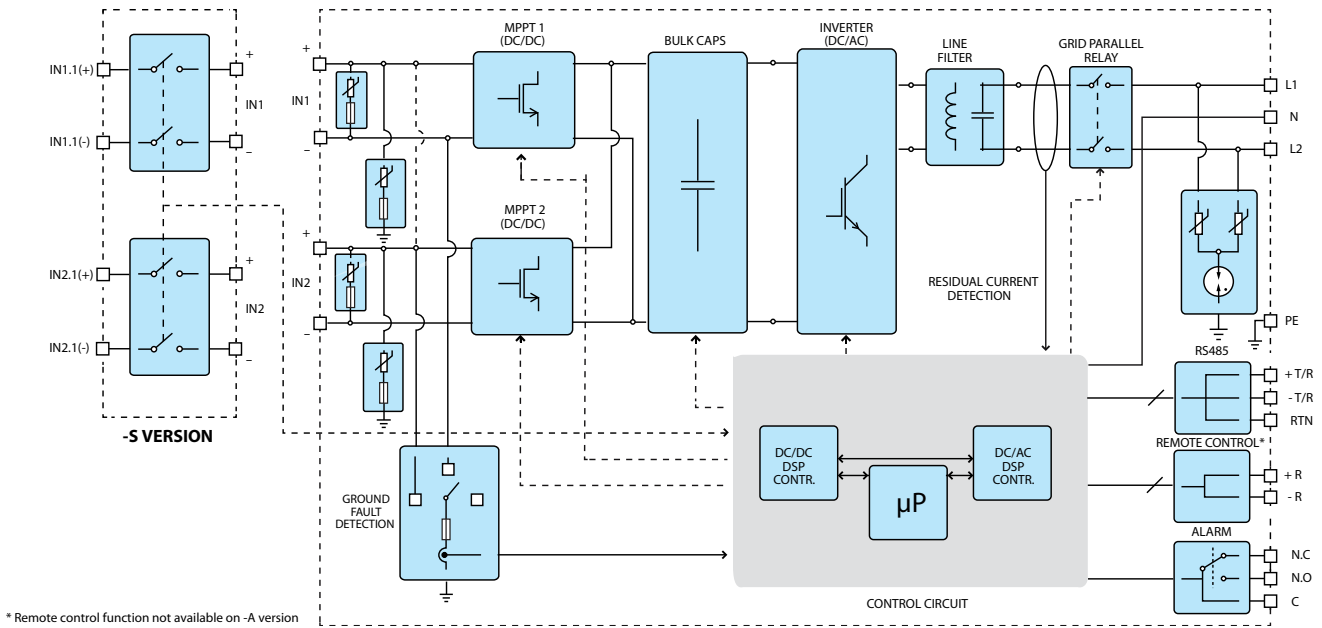

PVI-4.2-OUTD-US

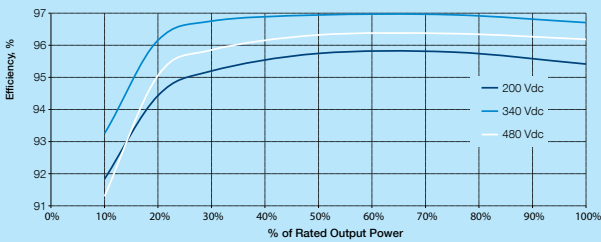

PVI-4.2-OUTD-US

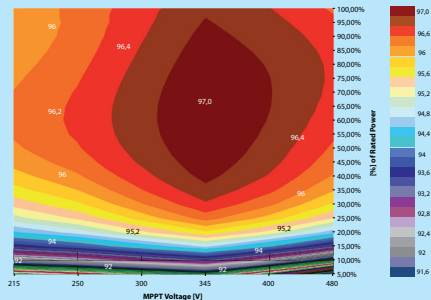

Technical data and types

Type code	PVI-3.0-OUTD-US	PVI-3.6-OUTD-US	PVI-3.8-OUTD-US	PVI-4.2-OUTD-US
Mechanical specifications				
Enclosure rating				NEMA 4X
Cooling				Natural convection
Dimensions (H x W x D)				33.8 x 12.8 x 8.7in (859 x 325 x 222mm)
Weight				<47.3lb (21.3kg)
Shipping weight				< 60lb (27.0kg)
Mounting system				Wall bracket
Conduit connections ²				Trade size KOs (2ea x 1/2") and (2ea x 1-1/4", 3 places side, front, rear) Side: (2) plugged 3/4" openings, (2) Concentric KOs 3/4", 1" Back: (4) Concentric EKO's 3/4", 1"
DC switch rating (per contact) (A/V)				25/600
Safety				
Isolation level				Transformerless (floating array)
Safety and EMC standard				UL 1741, IEE1547, IEE1547.1, CSA-C22.2N: 107.1-01, UL1998 UL 1699B, FCC Part 15
Safety Approval				Class B cCSAus
Warranty				
Standard warranty				10 years
Extended warranty				15 & 20 years
Available models				
Standard - without DC switch and wiring box	PVI-3.0-OUTD-US	PVI-3.6-OUTD-US	PVI-3.8-OUTD-US	PVI-4.2-OUTD-US
Standard - with DC switch and wiring box	PVI-3.0-OUTD-S-US	PVI-3.6-OUTD-S-US	PVI-3.8-OUTD-S-US	PVI-4.2-OUTD-S-US
With DC switch, wiring box and arc fault detector and interrupter	PVI-3.0-OUTD-S-US-A	PVI-3.6-OUTD-S-US-A	PVI-3.8-OUTD-S-US-A	PVI-4.2-OUTD-S-US-A

Support and service

ABB supports its customers with a dedicated, global service organization in more than 60 countries, with strong regional and national technical partner networks providing a complete range of life cycle services.

For more information please contact your local ABB representative or visit:

www.abb.com/solarinverters

www.abb.com

© Copyright 2014 ABB. All rights reserved. Specifications subject to change without notice.